

FITTING INSTRUCTIONS

IMN/IMP - 30 minutes Fire and Smoke Seal
 N60S/IMP - 60 minutes Fire and Smoke Seal

These seals are rebated into the edges of double-acting, double leaf pivot or hinge fire doors. It is essential that the correct width of rebate is cut as remedial work can cost time and money. We recommend that the groove be routed to give a 'light press fit' for the extrusion. The seal should finish flush with the timber.

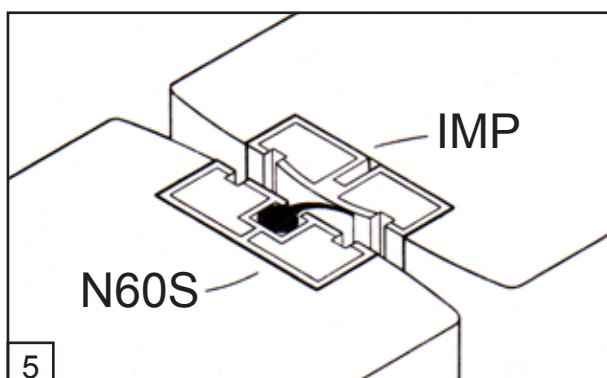
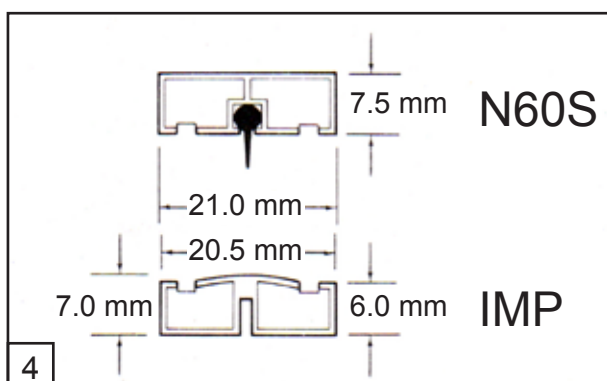
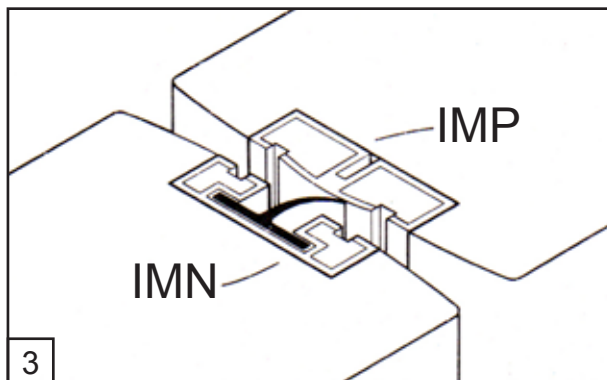
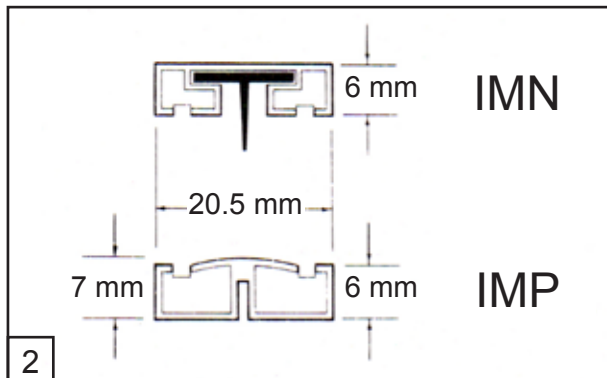
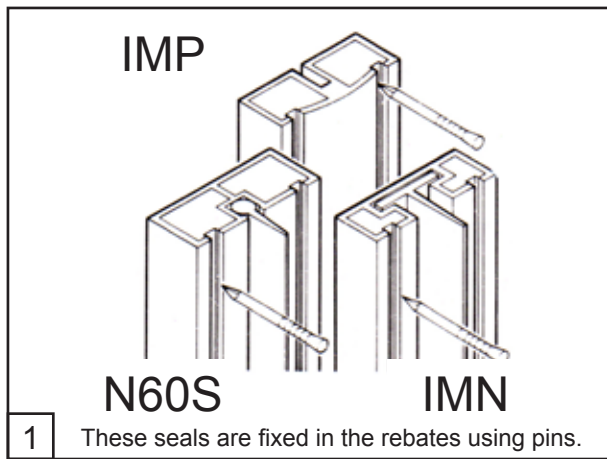

Seal	Extrusion Width	Extrusion Depth
IMN	20.5 mm	6.0 mm
IMP	20.5 mm	6.0 mm
N60S	21.0 mm	7.5 mm



The recommended door-to-door gap and door-to-frame gap is 3 mm.

FITTING IMN/IMP

On double leaf swing doors IMN is fitted into the edge of one meeting stile. It is also fitted into the head rails and hanging stiles of both doors. Alternatively, IMN may be fitted into the head and jambs of the door frame. IMP is fitted into the opposing meeting stiles of the second door. NOTE. At the meeting stiles the IMN blade insert must only make contact with the curved face of IMP and not with the door edge.

FITTING N60S/IMN

N60S/IMP is fitted in the same way as IMN/IMP.

Intumescent strips are supplied in standard lengths of 1050 mm to be cut to fit on site. Cut ends require no treatment and, if required, short ends may be used butted up to each other. Strips should be pinned every 200 mm or as required. All corners of timber components must be well rounded to prevent damage to the insert and ensure ease of adjustment. Solvent based glues, paints, varnishes etc. must not come into contact with neoprene inserts.

Sealmaster.

Brewery Road, Pampisford, Cambridge, CB22 3HG
 England.

Tel. (01223) 832851 / (Int.) 0044 1223 832851
 Fax (01223) 837215 / (Int) 0044 1223 837215

sales@sealmaster.co.uk
 technical@sealmaster.co.uk
 www.sealmaster.co.uk

Sealmaster is a Division of the Dixon International Group Limited.
 Registered Office: Brewery Road, Pampisford, Cambridge, England.
 CB22 3HG. Registered Number: 1845563.

The information given here is based on our general experience and tests and is intended for guidance only. Every effort is made to ensure that the data in this instruction sheet are correct and we do not accept liability for injury, loss or damage arising from reliance thereon. This data sheet does not form part of a contract and any difficulties arising from on-site conditions should be referred to our engineers for advice.